

Synthesis of N^π -2-adamantylloxymethylhistidine, His(N^π -2-Adom), and its evaluation for peptide synthesis

Yoshio Okada,* Jidong Wang,† Takeshi Yamamoto‡ and Yu Mu

Faculty of Pharmaceutical Sciences, Kobe Gakuin University, Nishi-ku, Kobe 651-21, Japan

N^π -2-Adamantylloxymethylhistidine, His(N^π -2-Adom), is prepared and successfully applied to the synthesis of thyrotropin-releasing hormone (TRH) in combination with *tert*-butyloxycarbonyl (Boc) as the N^α -protecting group. This new protecting group suppressed racemization during peptide synthesis and exhibited high solubility in organic solvents.

During peptide synthesis, the NH group in the imidazole ring of the histidine side chain should be protected to avoid unwanted side reactions, such as acylation, formation of DCC adducts¹ and side-chain induced racemization.² Various kinds of protecting group for the imidazole nitrogen of histidine residues have been developed in peptide synthesis and it has been found that protecting groups of the π -nitrogen of the imidazole function are better than those of the τ -nitrogen for preventing racemization during peptide synthesis. N^π -Benzyloxymethylhistidine, His(N^π -Bom), has been developed by Brown *et al.*³ The Bom group is stable to $\text{CF}_3\text{CO}_2\text{H}$ (TFA) and alkaline conditions and cleavable by hydrogenation over a Pd catalyst or with HF.⁴ Therefore, His(N^π -Bom) can be used for peptide synthesis in combination with *tert*-butyloxycarbonyl (Boc) or fluoren-9-ylmethyloxycarbonyl (Fmoc) as N^α -protecting groups. The latter derivative can be used in convergent solid-phase peptide synthesis, which involves the preparation of partially protected peptide fragments by stepwise solid-phase peptide synthesis, followed by purification and their assembly on solid supports.⁵

The convergent solid phase method is useful for the preparation of fairly large peptides. With this method, the protected peptide fragments have to be highly soluble, since the fragment must be easily removable by washing with an organic solvent after fragment condensation on the resin. With this in mind, we aimed to develop a new protecting group for the π -nitrogen of the imidazole function, which would exhibit similar stability in acids and bases to the Bom group, high solubility in organic solvents and suppress side reactions such as side-chain induced racemization. Previously, we have reported that the 2-adamantyl ester (2-Ada) employed for protection of the β -carboxy function of aspartic acid (Asp), was suitably soluble in organic solvents and stable to acids,^{6,7} while the 1-adamantyl ester (1-Ada) was susceptible to acid. The above results provided us with an idea to design a novel N^π -protecting group.

This paper deals with the synthesis of His(N^π -2-Adom) (Fig. 1), examination of its properties and its application to the synthesis of thyrotropin-releasing hormone (TRH), by solution and solid-phase methods.

First of all, as shown in Scheme 1, 2-adamantylloxymethyl chloride (2-Adom-Cl) was prepared by the reaction of 2-adamantylloxymethyl methyl sulfide and sulfur dichloride. 2-

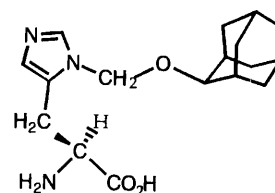

Fig. 1 Structure of H-His(N^π -2-Adom)-OH

Adom-Cl was treated with Boc-His(N^τ -Boc)-OMe to afford Boc-His(N^π -2-Adom)-OMe,[§] which was saponified with NaOH (1 mol dm⁻³) to give Boc-His(N^π -2-Adom)-OH.[¶] H-His(N^π -2-Adom)-OH was derived from Boc-His(N^π -2-Adom)-OH on treatment with TFA.

Next, the stability and susceptibility of the 2-Adom group to various acids and bases were examined by measurement of the regenerated His residue and intact H-His(N^π -2-Adom)-OH (retention time: 54.2 min) on an amino acid analyser. The 2-Adom group is stable to TFA and piperidine-DMF (20%) at room temperature up to 48 h and rapidly cleaved by trifluoromethanesulfonic acid (TFMSA)-thioanisole-TFA (1 mol dm⁻³) or anhydrous HF.⁴ These results indicate that His(N^π -2-Adom) can be used for peptide synthesis in combination with both Boc and Fmoc as N^α -protecting groups in solution and by solid-phase methods.

The efficiency of the N^π -2-Adom group in preventing side chain induced racemization was also examined. Boc-D-His(N^π -2-Adom)-L-Gln-OBzl can be readily separated from Boc-L-His(N^π -2-Adom)-L-Gln-OBzl by HPLC,^{||} and therefore this sequence was employed as a model study on racemization. Boc-L-His(N^π -2-Adom)-OH was coupled with H-L-Gln-OBzl by DCC, DCC-HOBt, benzotriazol-1-yloxytris(dimethylamino)phosphonium hexafluorophosphate (BOP),⁸ 2-(1*H*-benzotriazol-1-yl)-1,1,3,3-tetramethyluronium hexafluorophosphate (HBTU)⁹ or diphenylphosphoryl azide (DPPA),¹⁰ and the crude product was analysed by HPLC. The results summarized in Table 1 show that the formation of the D-L peptide was very low in all the coupling methods so far examined.

Finally, Boc-His(N^π -2-Adom)-OH was employed to synthesize thyrotropin-releasing hormone (TRH) in both solution and by solid phase methods as shown in Figs. 2 and 3, respectively.

For the solution method, the protected tripeptide, after purification by silica gel column chromatography, was treated with TFMSA-thioanisole-TFA (1 mol dm⁻³) as usual to give

§ Mp 114–115 °C; δ_{H} (400 MHz; CDCl_3 ; Me_4Si) 1.42–2.02 (23 H, Bu + adamantyl), 3.12–3.23 (2 H, m, CH_2CH), 3.51 (1 H, m, CHO), 3.73 (3 H, s, OCH_3), 4.59–4.60 (1 H, m, CHCH_2), 5.29–5.33 (3 H, m, CONH + CH_2OAda), 6.83 (1 H, s, 5^{im}-H), 7.50 (1 H, s, 2^{im}-H); $[\alpha]_{\text{D}} -8.2$ (c 0.5 in MeOH), satisfactory elemental analysis.

¶ Mp 173–174 °C, $[\alpha]_{\text{D}} +5.6$ (c 1.0 in MeOH), satisfactory elemental analysis.

|| Column: Cosmosil pack 5C 18-AR (4.6 × 250 mm); eluent: A (0.05% TFA in water): B (0.05% TFA in MeCN) = 63:37 to 50:50 for 50 min, and to 63:37 for 5 min; flow rate: 1 cm³ min⁻¹.

† J. W. is a visiting scientist from the Department of Molecular Biology of Jilin University, China.

‡ Present address: New Drug Research Laboratories, Kanebo Ltd., 5–9 Tomobuchi-cho, 1-chome, Miyakojima-ku, Osaka 534, Japan.

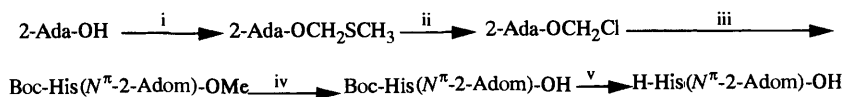

Scheme 1 Synthetic scheme for Boc-His(N^π-2-Adom)-OH. Reagents and conditions: i, DMSO, Ac₂O; ii, SO₂Cl₂; iii, Boc-His(N^π-Boc)-OMe; iv, aq. NaOH (1 mol dm⁻³); v, TFA.

Table 1 Extent of racemization during the coupling of Boc-His(N^π-2-Adom)-OH and H-Gln-OBzl; DL (%) is given as DL/(LL + DL)

Coupling method	DL (%)
DCC	2.45
DCC-HOBt	0.92
BOP	0.74
HBTU	0.70
DPPA	0.76

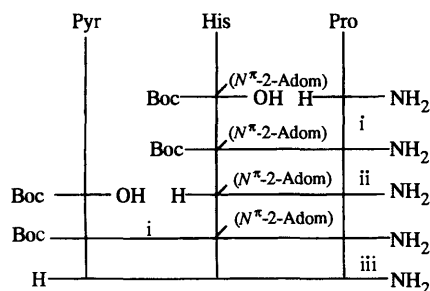

Fig. 2 Synthetic scheme for TRH in solution method. Reagents and conditions: i, BOP (1.2 equiv.), HOBt (1.2 equiv.), NMM (1.8 equiv.); ii, HCl-dioxane (7.6 mol dm⁻³), 0 °C, 1 h; iii, TFMSA-thioanisole-TFA (1 mol dm⁻³), 0 °C, 1 h.

TRH. The TRH thus obtained exhibited a single peak by analytical HPLC with the same retention time** as that of authentic TRH purchased from the Peptide Institute (Osaka, Japan). Using the solid-phase method, TRH was constructed on a 4-methylbenzhydrylamine (MBHA) resin according to Fig. 3. The protected peptide resin thus obtained was treated with HF and the crude product was purified by preparative HPLC. The purified synthetic TRH exhibited a single peak by analytical HPLC with the same retention time as that of authentic TRH.

Acknowledgements

We are grateful to Dr Toshio Yokoi of Kobe Gakuin University for his valuable advice about NMR data. This work was

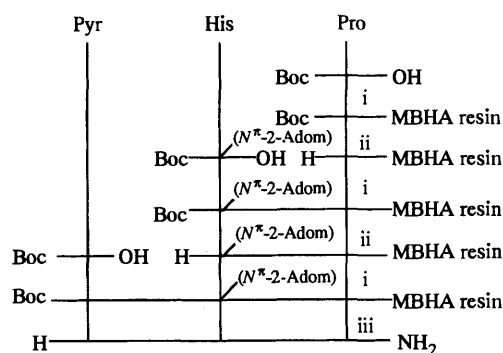

Fig. 3 Synthetic scheme for TRH in solid phase method. Reagents and conditions: i, Boc-AA (3.0 equiv.), BOP (3.6 equiv.), HOBt (3.6 equiv.), NMM (5.4 equiv.); ii, (a) 50% TFA-CH₂Cl, (b) Et₃N-DMF; iii, HF (2 equiv. thioanisole), 0 °C, 1 h.

supported in part by a grant from The Science Research Fund of the Japan Private School Promotion Foundation.

References

- H. Rink and B. Riniker, *Helv. Chim. Acta*, 1974, **57**, 831.
- J. H. Jones, W. I. Ramage and M. J. Witty, *Int. J. Pept. Protein Res.*, 1980, **15**, 301.
- T. Brown, J. H. Jones and J. D. Richards, *J. Chem. Soc., Perkin Trans. 1*, 1982, 1553.
- S. Sakakibara, Y. Shimonishi, Y. Kishida, M. Okada and U. Sugihara, *Bull. Chem. Soc. Jpn.*, 1967, **40**, 2164.
- F. Albercio, P. L. Williams, M. Gairi, G. Jou, C. Celma, N. K. Coudonier, A. Grandas, R. Eritja, E. Pedroso, J. van Reitschoten, G. Barany and E. Giralt, in *Innovation and Perspectives in Solid Phase Synthesis; Peptides, Polypeptides and Oligonucleotides*, ed. R. Epton, Intercept Ltd., Andover, 1992, p. 39.
- Y. Okada and S. Iguchi, *J. Chem. Soc., Perkin Trans. 1*, 1988, 2129.
- K. Nokihara, H. Hellstern and G. Hofle, in *Peptide Chemistry, Structure and Biology* (Proceedings of the 11th American Peptide Symposium), ed. J. E. Rivier and G. R. Marshall, ESCOM, Leiden, 1990, p. 1046.
- B. Castro, J. R. Dormoy, G. Evin and C. Selve, *Tetrahedron Lett.*, 1975, **14**, 1219.
- R. Knorr, A. Trzeciak, W. Bannwarth and D. Gillessen, *Tetrahedron Lett.*, 1989, **30**, 1927.
- T. Shioiri, K. Ninomiya and S. Yamada, *J. Am. Chem. Soc.*, 1972, **94**, 6203.

** Column: Cosmosil pack 5C 18-AR (4.6 × 250 mm); eluent: A (0.05% TFA in water): B (0.05% TFA in MeCN) = 90:10 (isocratic); flow rate: 0.5 cm³ min⁻¹.